

PTCC-01 SERIES

Programmable, smart thermoelectric cooler controllers

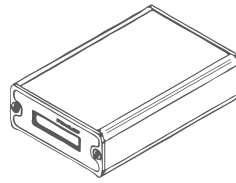

PTCC-01-ADV

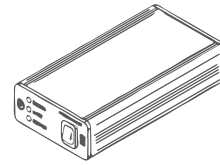

PTCC-01-BAS

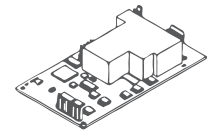

PTCC-01-OEM

OPTIONS

PTCC-01-ADV

- TEC controller and preamplifier power supply encapsulated in a small-size package.
- Configurable by built-in function keys or PC software available on the VIGO website.
- Status LCD indicator.
- IR module socket: D-sub 9 pins
- Power supply socket: DC 2.1/5.5

PTCC-01-OEM

- TEC controller and preamplifier power supply without package.
- Configurable by PC software available on the VIGO website.

PTCC-01-BAS

- TEC controller and preamplifier power supply encapsulated in a small-size package.
- Configurable by PC software available on the VIGO website.
- Status LED indicator.
- IR module socket: D-sub 9 pins
- Power supply socket: DC 2.1/5.5

- Status LED indicator and status/data connector.
- IR module socket: DUBOX 2x5
- Power supply socket: KK2

VIGO IR DETECTION MODULES THAT CAN OPERATE WITH PTCC-01 SERIES

SELECTED LINE

- **LabM-I-4** detection module (p. 98)
- **LabM-I-5** detection module (p. 101)
- **LabM-I-6-01** detection module (p. 104)
- **LabM-I-10.6** detection module (p. 107)
- **SM-I-12** detection module (p. 122)
- IR detection modules containing TE-cooled detectors in the TO8 package and preamplifiers:
 - **PIP** series (p. 129)
 - **MIP** series (p. 132)
 - **SIP-TO8** series (p. 135)
 - **FIP** series (p. 141)

INCLUDED ACCESSORIES

PTCC-01-ADV, PTCC-01-BAS

- Smart Manager software (freeware)
- 1 pc of USB: TypeA-MicroB cable
- 1 pc of AC adaptor

PTCC-01-OEM

- Smart Manager software (freeware)
- 1 pc of USB: TypeA-MicroB cable
- 1 pc of KK2-POWER cable

SCHEMATIC DIAGRAM

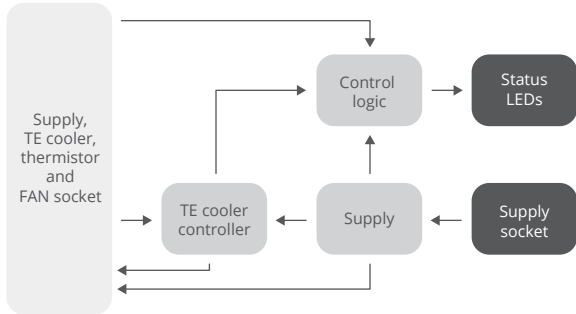

SPECIFICATION ($T_{amb} = 293\text{ K}$)

Parameter	Conditions/ remarks	Value			Unit
		Min.	Typ.	Max.	
Temperature stability		-	±0.01	-	K
Temperature readout stability		-	-	1.0	mK
Detector temperature settling time, s	2TE	-	25	-	s
	3TE	-	45	-	
	4TE	-	60	-	
Maximum TEC output current	2TE	-	1.2	-	A
	3TE	-	0.45	-	
	4TE	-	0.4	-	
IR module positive power supply output voltage range		+3.0	-	+14.5	V
IR module negative power supply output voltage range		-14.5	-	-3.0	V
IR module power supply output current		-	-	±200	mA
TEC controller input power supply voltage range		9.0	-	16.0	V _{DC}
TEC controller power supply current consumption	$I_{TEC} = 0.45\text{ A}$, $U_{TEC} = 7.5\text{ V}$	-	500	-	mA
Maximum total resistance of the wires supplying TEC element	Resistances higher than specified may limit minimum temperatures that the controller can stabilize	-	1.0	-	Ω
Weight	PTCC-01-ADV	-	190	-	g
	PTCC-01-BAS	-	150	-	
	PTCC-01-OEM	-	50	-	

MECHANICAL LAYOUT (Unit: mm)

PTCC-01-BAS

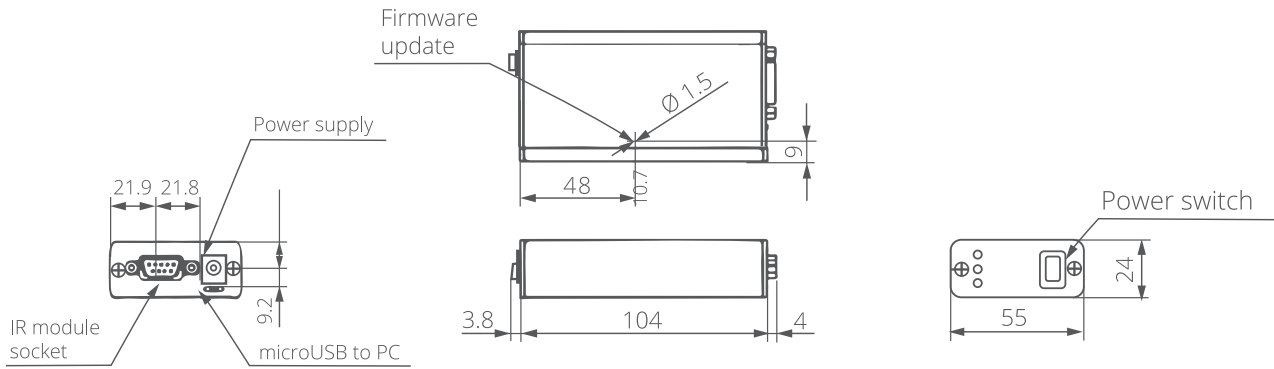

PTCC-01-ADV

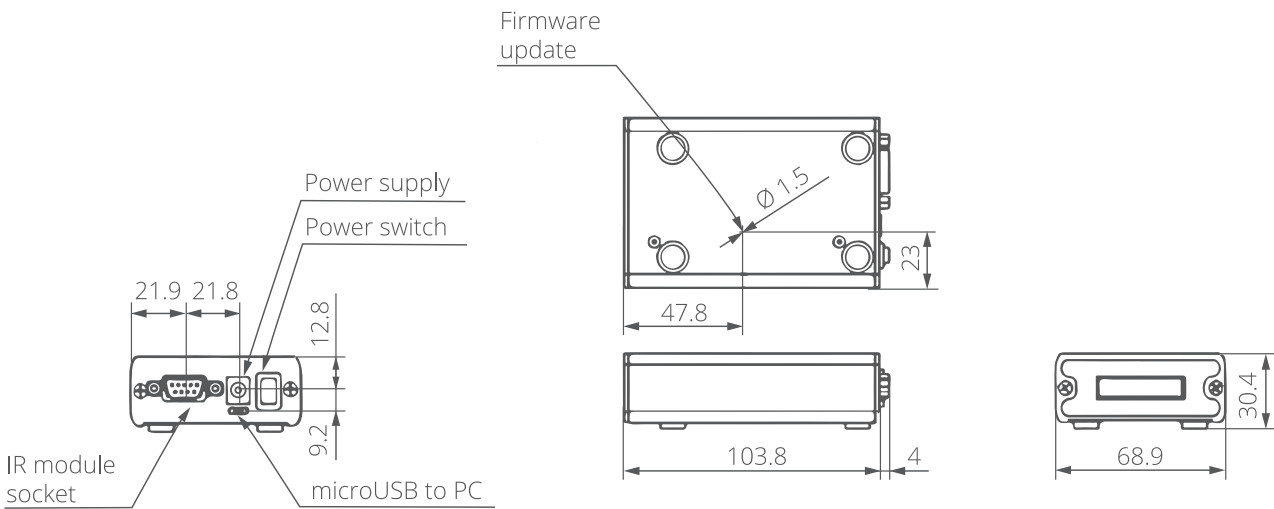

IR MODULE SOCKET PINOUT

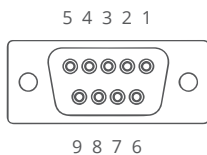

D-SUB 9 PIN

Pin No.	Symbol	Function
1	TEC+	TEC supply output (+)
2	TEC-	TEC supply output (-)
3	GND	IR module power supply ground
4	TH1	Thermistor input (1)
5	TH2	Thermistor input (2)
6	-Vsup	IR module power supply output (-)
7	+5V	FAN and programmable preamp internal logic auxiliary supply
8	DATA	Bidirectional data port
9	+Vsup	IR module power supply output (+)
Metal cover	GND-SH	Shield

MECHANICAL LAYOUT (Unit: mm)

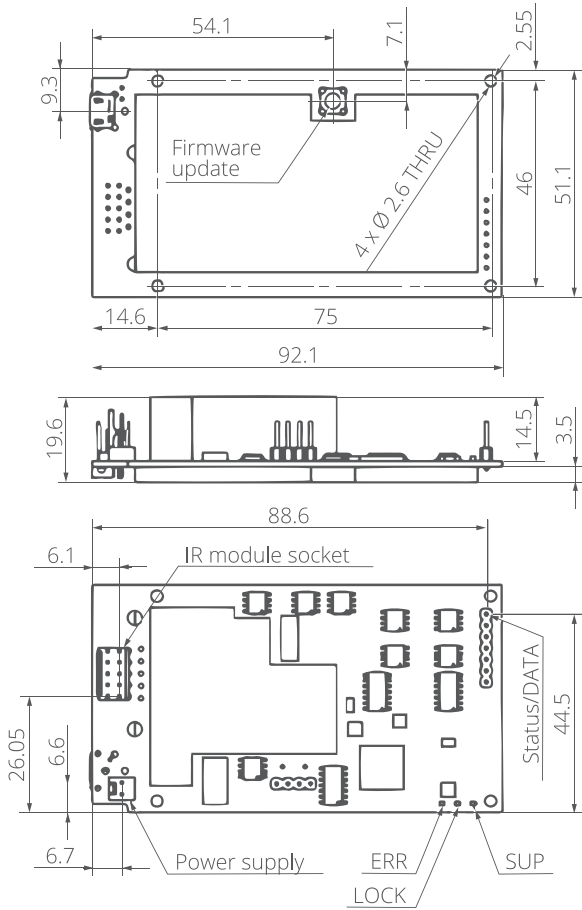

PTCC-01-OEM

STATUS/DATA SOCKET PINOUT



Pin No.	Symbol	Function
1	ERR-LED	Error indicator
2	LOCK-LED	Temperature control loop lock indicator
3	SUP-LED	Module power supply on indicator
4	3.3 V	Auxiliary supply
5	TXD	Transmitted data (RS-232)
6	GND	Common (signal) ground (RS-232)
7	RXD	Received data (RS-232)

POWER SUPPLY SOCKET PINOUT

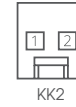

Pin No.	Symbol	Function
1	PTCCsup+	TEC controller supply input (+)
2	PTCCsup-	TEC controller supply input (-)

IR MODULE SOCKET PINOUT

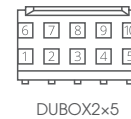

Pin No.	Symbol	Function
1	TEC+	TEC supply output (+)
2	TEC-	TEC supply output (-)
3	GND	IR module power supply ground
4	TH1	Thermistor input (1)
5	TH2	Thermistor input (2)
6	-Vsup	IR module power supply output (-)
7	+5V	FAN and programmable preamp internal logic auxiliary supply
8	DATA	Bidirectional data port
9	+Vsup	IR module power supply output (+)
10	GND-SH	Shield

ABSOLUTE MAXIMUM RATINGS

Parameter	Test conditions/remarks	Value	Unit
Ambient operating temperature, T_{amb}		5 to 45	°C
Storage temperature, T_{stg}		-20 to 70	°C
Humidity	No dew condensation	10 to 90	%

Stresses beyond those listed under Absolute maximum ratings may cause permanent damage to the device. Constant or repeated exposure to absolute maximum rating conditions may affect the quality and reliability of the device.